



SOCI

ADA-5202 Kitchen Sink



FEATURES

- Premium 304 series stainless steel construction
- Undercoating and sound deadening pads to absorb noise and maintain water temperature
- 18/8 chrome-nickel content
- ADA compliant
- Optional strainer accessories available

TECHNICAL DATA

Model #	Material	Finish	Mount Options	Overflow	Drain Size	ADA Compliant	Gauge
ADA-5202	Stainless Steel	Satin	Under-mount	No	3-1/2"	Yes	18G

TECHNICAL DRAWING

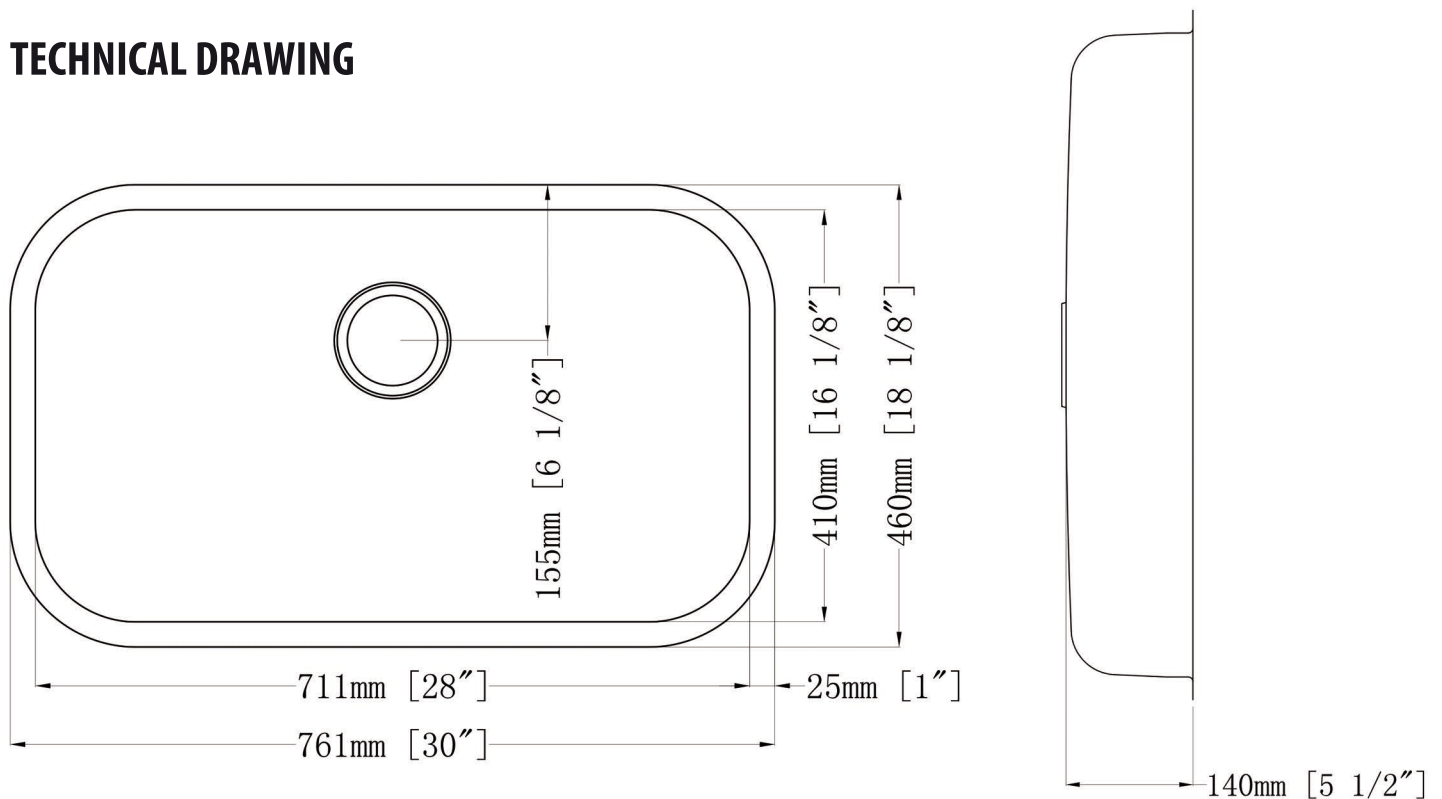

www.soci.design

718 South Greenville Ave. Ste 190 Allen, TX 75002

Phone: (214) 585-4900

Email: sales@soci.design